

S SIERRA EQUIPMENT INC.

Premier Technology®

2012

Swimming Pool Equipment



8505 N.W. 29 Street
Miami, Florida 33122
PHONE: (305) 592-0224
FAX: (305) 592-0225

EMAIL: sales@sierraequipment.com
www.sierraequipment.com

TABLE OF CONTENT

FILTERS & ACCESSORIES

Sand Dollar Filters	1
Sand Storm Filter	2
Triton II Side Mount Sand Filters	3
Clean & Clear Cartridge Filters	4
Multiport Valve Kit.....	3

PUMPS

WhisperFlo High Performance Pumps.....	5
WhisperFlo 50 HZ High Performance Pumps	6
WhisperFlo 3-Phase High Performance Pump	7
SuperFlo Pool Pumps	8
Dynamo Pool Pumps.....	9
Challenger High Flow Pool Pumps.....	10

FITTINGS AND ACCESSORIES

Bermuda Skimmers for Gunitite Pools.....	11
Bermuda Skimmer Accessories.....	11
Anti-Vortex Main Drain	11
Commercial Main Drains	12
Commercial Drain Frame & Grates.....	12
Pool Wall Fittings.....	13
Directional Inlet Fittings.....	13
Insider Directional Inlets	13
Single Entry PVC Ball Valves.....	30

UNDERWATER POOL LIGHTS & ACCESSORIES

IntelliBrite® LED Color-Changing Light.....	14
Amerlite Incandescent Pool Lights	15
Stainless Steel Niche for Concrete Pools	15
Pool Junction Box	16
Stainless Steel Pool Transformers.....	16
Pool Replacement Lamps.....	15

RAIL GOOD & ACCESSORIES

24" Residential Ladders	17
Deck Mounted Stair Rail	17
2 Bend Standard Length Hand Rails	18
Stainless Steel Escutcheon Plates.....	18
Ladder Anchors with Ground.....	18

POOL HEATERS

MiniMax 100 High Performance Heaters	19
Master Temp High Performance Heaters	20
ThermalFlo Heat Pumps.....	21

MAINTENANCE EQUIPMENT

Residential Chlorine Generators.....	22 & 22A
Robotic Inground Pool Cleaners	23
Suction-Side Inground Pool Cleaners	24
Vac-Mate Controller for Suction Cleaners.....	24
Flexible Pool Vacuums for Concrete Pools.....	24
Leaf Skimmers.....	25
Leaf Rakes	25
Telescoping Poles	25
Deluxe Wall Brush	26
Deluxe Algae Brush	26
Pool Vacuum Hoses	26
Thermometer	27
Water Test Kits.....	27
Chlorine Floating Dispensers	27
Rainbow Automatic Chlorine Feeders	28

POOL ELECTRICAL CONTROLS

Time Switches	29
---------------------	----

POOL WATER FEATURES

Deck Jet	31
Deck Level Stream Jet.....	32
FyreFly Jet.....	33
Oasis Original Waterfall.....	34
Oasis Rainforest Waterfall	34
Oasis Arch Fall.....	35

REPLACEMENT PARTS

Filter Elements	30
Chlorine Generators Parts	36

Cristal-FloII™ Top Mount Sand Filters



Features

Their unique, patented process creates a one-piece, non-corrosive tank with superior strength and durability. The Cristal-FloII filter features a clamp style, six-position multiport valve. Special lateral design provides superior flow characteristics and long filter cycles for economical operation.

Maximum Operating Pressure 35 psi

Performance

Model No.	Filtration Area	Flow Rate	Turnover Capacity (In Gallons)			Sand Required
			8 hour	10 hour	12 hour	
145360	1.8 Sq/Ft	40	19,200	24,000	28,800	150lbs.
145361	2.3 Sq/Ft	60	28,800	36,000	43,200	200lbs.
145363	3.5 Sq/Ft	75	36,000	45,000	54,000	350lbs.

Dimensions

Model	A Dim	B Dim	C Dim
145360	37"	19-1/2"	46"
145361	38-1/2"	22-1/2"	50-1/2"
145363	47-7/8"	26"	74"

Clearance to remove valve and internal piping

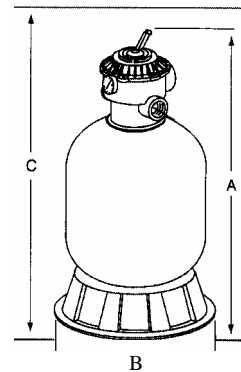

Ordering Number

Ordering Number	Description	Weight
PP145360	19-1/2" Cristal FloII Top Mount Filter w/ Multiport Valve	24lbs
PP145361	22-1/2" Cristal FloII Top Mount Filter w/ Multiport Valve	28lbs.
PP145363	26" Cristal FloII Top Mount Filter w/ Multiport Valve	76lbs.

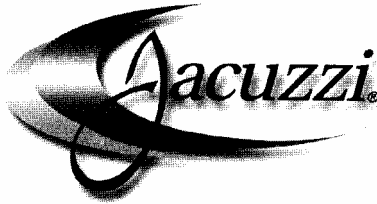

Sand Storm Sand Filter

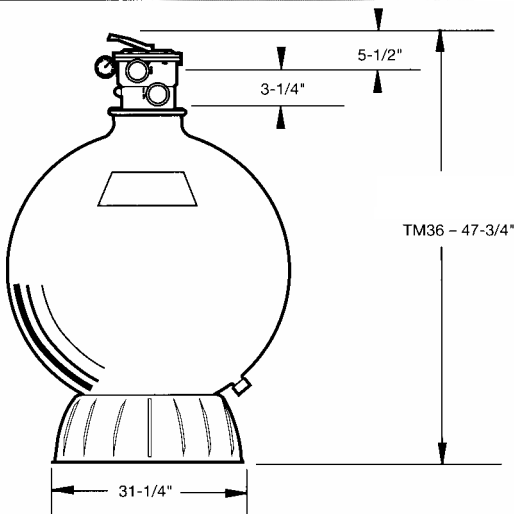

Features

- **The SandStorm** features a corrosion resistant and ultra violet resistant, precision molded one piece tank.
The 36" handles commercial flows up to 140 GPM and residential flows up to 175 GPM.
- **Spherical tank design** for superior strength, longer life.
- **Stainless Steel Clamp** allows for 360 degree rotation of dial valve for easy installation.
- **2" plumbing** for less flow restriction.
- **Sturdy injection molded base** for secure tank support.
- **7-way dial valve controls** filter, backwash, rinse, drain, whirlpool, winterize, and test operations. The 2" valve features large waterways for better flow.
- **Uniflo underdrain** with the exclusive **snowflake lateral** system which optimizes use of sand bed on large filters.
- **Water distribution system** features unique diverter and basket to direct water evenly across the entire surface of the sand without sand migration or channeling.

Performance

Model No.	sq/ft.	Total Gallons Circulated				Sand
		Residential		Commercial		
		6hrs.	8hrs.	6hrs.	8hrs.	
TM36	7.05	63,450	84,600	50,760	67,680	800lbs.

Ordering Number:	Model No.	Description	Weight
AP94080036	TM36-7	36" Sand Filter with 7-way Dial Valve	150lbs.

Triton II Side Mount Sand Filter Without Valves

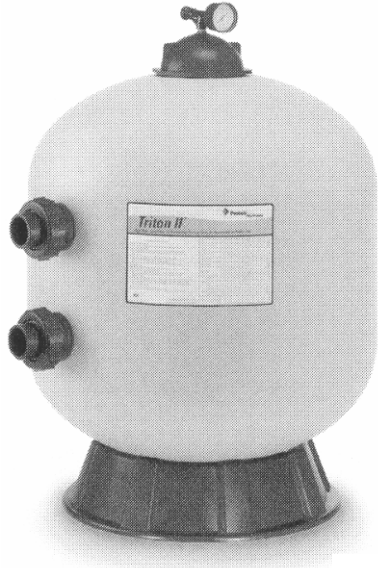

Features

The original and still the industry standard. Their patented GlasLock™ process creates a one-piece, fiberglass reinforced tank with UV resistant surface finish for years of unequaled strength and durability.

This unique method locks in fiberglass, preventing fibers from “blooming” under harsh conditions.

Heavy-duty closure provides easy inspection, and features an easy-to-read pressure gauge with air relief valve. Swing-away diffuser allows instant access to sand and all internal parts, which are tumbled for easy installation and service. Internal air bleed.

Bulkhead connectors are threaded for easy installation and service. Maximum Operating Pressure 50 psi.

Dimensions

Model	A. Dim.	B. Dim.	C. Dim.	D. Dim.
TR100	39-3/4”	30-1/2”	16-1/4”	41-3/4”
TR140	45-1/4”	36-1/2”	18-3/4”	47-1/4”

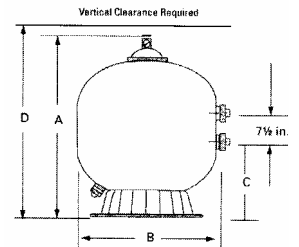

Performance

Model	sq/ft	Flow Rate	Turnover Capacity In Gallons			
			8 hour	10 hour	12 hour	Sand
TR100	4.91	98 gpm	47,040	58,800	70,560	600lbs.
TR140	7.06	141gpm.	67,680	84,600	101,520	925lbs.

Ordering Number	Model	Description	Weight
PP140210	TR100	30” Triton II Sand Filter without Valve	65lbs.
PP140243	TR140	36” Triton II Sand Filter without Valve	75lbs.

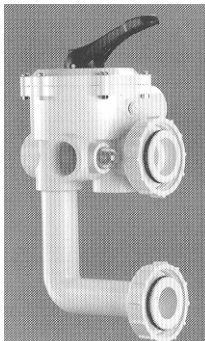

Multiport Valve Kit

Features

Side Mounted Multiport Valve is designed for maximum performance and working pressure. PVC body. Six position, positive-lock operation. 2” Slip with Unions

Ordering Number	Description	Weight
PP261055	2” Multiport Valve for Sand Filter	9lbs.

Clean & Clear® Cartridge Filters



Fiberglass Reinforced Polypropylene Tank

Features

The Clean & Clear® Filter features a chemical resistant tank with no-tool servicing and coreless cartridge for easier cleaning. All models are equipped with easy spin-on unions for plumbing hook-ups. These filters are NSF listed for commercial applications. It has an integrated continuous High Flow™ internal air relief in operation only when there is unobstructed flow in the circulating system

Performance

Model No.	Area	Flow Rate	Turnover Capacity in Gallons		
			8 hour	10 hour	12 hour
CC50	50	50	24,000	30,000	36,000
CC75	75	75	36,000	45,000	54,000
CC100	100	100	48,000	60,000	72,000
CC150	150	150	72,000	90,000	108,000
CC200	200	200	72,000	90,000	108,000

Ordering Number	Model No.	Description	Weight
PP160314	CC50	50 Sq. Ft. Cartridge Filter	15lbs.
PP160315	CC75	75 Sq. Ft. Cartridge Filter	26lbs.
PP160316	CC100	100 Sq. Ft. Cartridge Filter	33lbs.
PP160317	CC150	150 Sq. Ft. Cartridge Filter	35lbs.
PP160318	CC200	200 Sq. Ft. Cartridge Filter	35lbs.

Dimensions

Model No.	A Dim	B Dim.
CC50	18"	30"
CC75	25-1/2"	39"
CC100	33"	61"
CC150	40-1/2"	76"
CC200	40-1/2"	76"

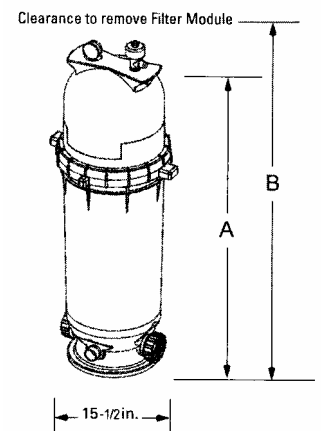

WhisperFlo® High Performance Pumps

Features

40% glass-filled thermoplastic with the Cam & Ramp™ “see thru” lid design. Self-priming, high flo with patented Funnel-Flo™ diffusers. 2” suction and discharge ports. Motor features threaded shaft and durable commercial duty 56 frame motor with NEMA square flange. It has oversized strainer basket and volute. With lower hp’s deliver higher performance than the industry standard. The WhisperFlo® heavy-duty construction is designed for long life, residential and commercial applications



Performance

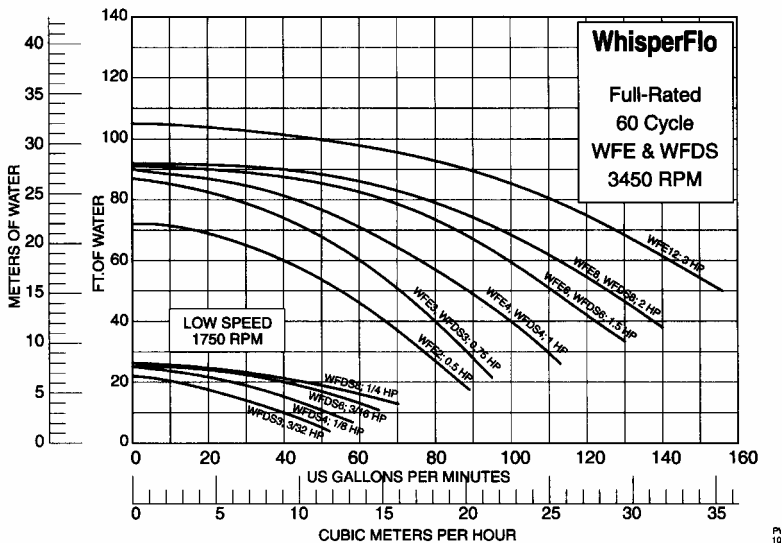

Dimensions

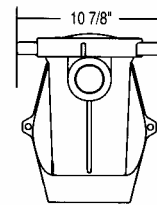
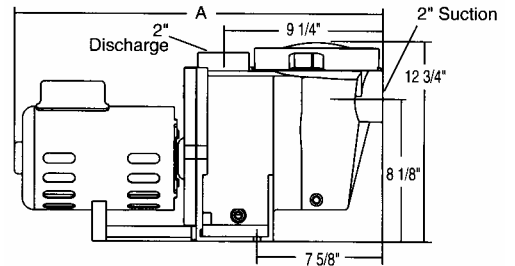

A - varying length:

- ½ & ¾ hp = 24.469"
- 1 hp = 24.72"
- 1½ hp = 25.22"
- 2 & 3 hp = 25.72"

Ordering Number	Model No.	HP	Voltage	Full Load Amps	Weight(Lbs.)
PP011771	WF-23	¾	115/230V	10.5/5.4	41
PP011772	WF-24	1	115/230V	14.2/7.1	41
PP011773	WF-26	1-1/2	115/230V	16/8	46
PP011774	WF-28	2	115/230V	22.4/11.2	54
PP011775	WF-30	2-1/2	230V	11	55
PP011516	WFE-12	3	230V	15	56

WhisperFlo® 50 HZ High Performance Pumps

Features

40% glass-filled thermoplastic with the Cam & Ramp™ “see thru” lid design. Self-priming, high flo with patented Funnel-Flo™ diffusers. 2” suction and discharge ports. Motor features threaded shaft and durable commercial duty 56 frame motor with NEMA square flange. It has oversized strainer basket and volute. With lower hp’s deliver higher performance than the industry standard. The WhisperFlo® heavy-duty construction is designed for long life, residential and commercial applications



Performance

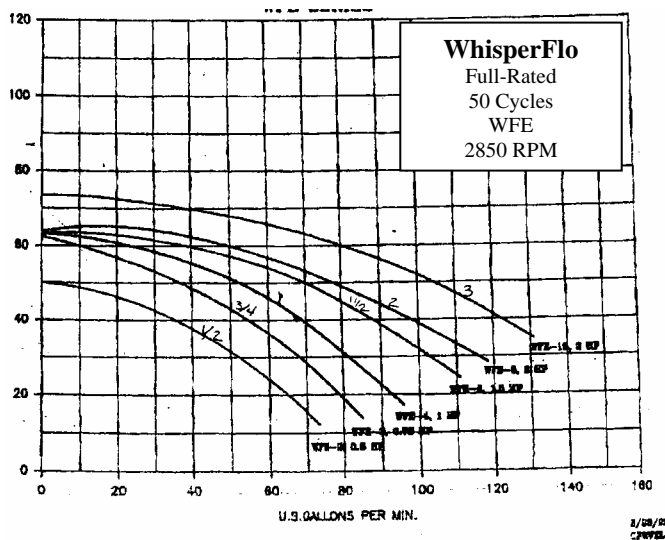

Dimensions

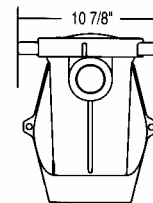
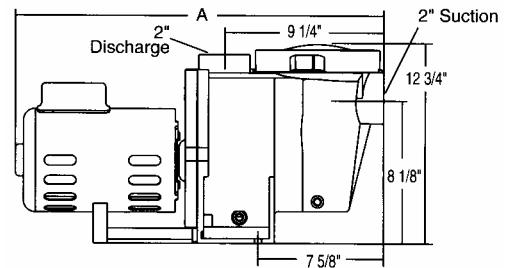

A - varying length:

- ½ & ¾ hp = 24.469"
- 1 hp = 24.72"
- 1½ hp = 25.22"
- 2 & 3 hp = 25.72"

Ordering Number	Model No.	HP	Voltage	Full Load Amps	Weight(Lbs.)
PP347927	WFE-3	¾	110/220V	11.2/5/6	41
PP347928	WFE-4	1	110/220V	14.8/7.8	46
PP347929	WFE-6	1-1/2	110/220V	19.6/8.8	54
PP347930	WFE-8	2	220V	11	55

WhisperFlo® 3-Phase High Performance Pumps

Features

40% glass-filled thermoplastic with the Cam & Ramp™ “see thru” lid design. Self-priming, high flo with patented Funnel-Flo™ diffusers. 2” suction and discharge ports. Motor features threaded shaft and durable commercial duty 56 frame motor with NEMA square flange. It has oversized strainer basket and volute. With lower hp’s deliver higher performance than the industry standard. The WhisperFlo® heavy-duty construction is designed for long life, residential and commercial applications



Performance

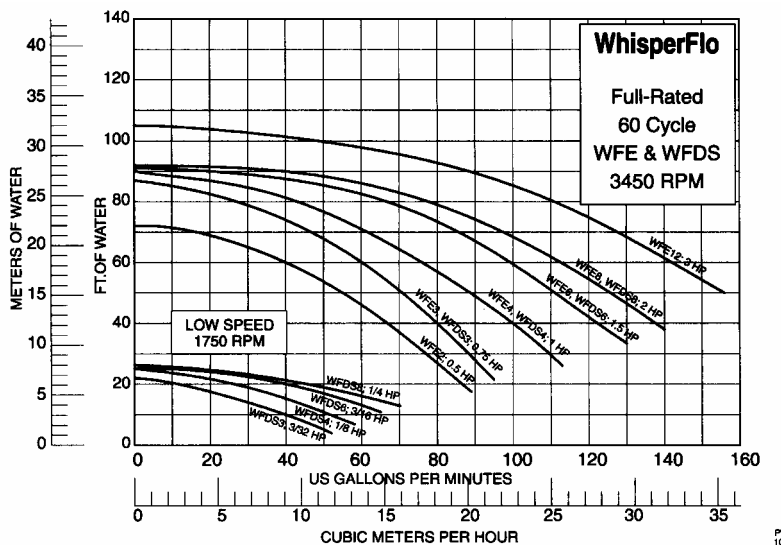

Dimensions

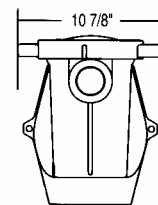
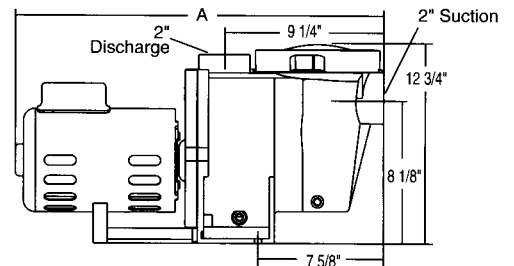

A - varying length:

- ½ & ¾ hp = 24.469"
- 1 hp = 24.72"
- 1½ hp = 25.22"
- 2 & 3 hp = 25.72"

Ordering Number	Model No.	HP	3-ph Voltage	Full Load Amps	Weight(Lbs.)
PP011021	WFK-3	¾	208/230/460V	3.8/3.6/1.8	42
PP011568	WFK-4	1	208/230/460V	5.0/4.6/2.3	46
PP011569	WFK-6	1-1/2	208/230/460V	6.4/5.8/2.9	54
PP011570	WFK-8	2	208/230/460V	7.1/6.8/3.4	56
PP011571	WFK-12	3	208/230/460V	11/10.4/5.2	58

SuperMax® Pool



Features

The Super Max® pumps are specifically designed to be the best choice for a variety of inground pools. The SuperMax features thick walled body parts, a heavy-duty 56 square flange motor, and highly engineered hydraulics. Its silent running capability and small footprint allow it to easily drop into a compact equipment pad. It includes unions (1-1/2" internal slip and 2" external slip).



Performance

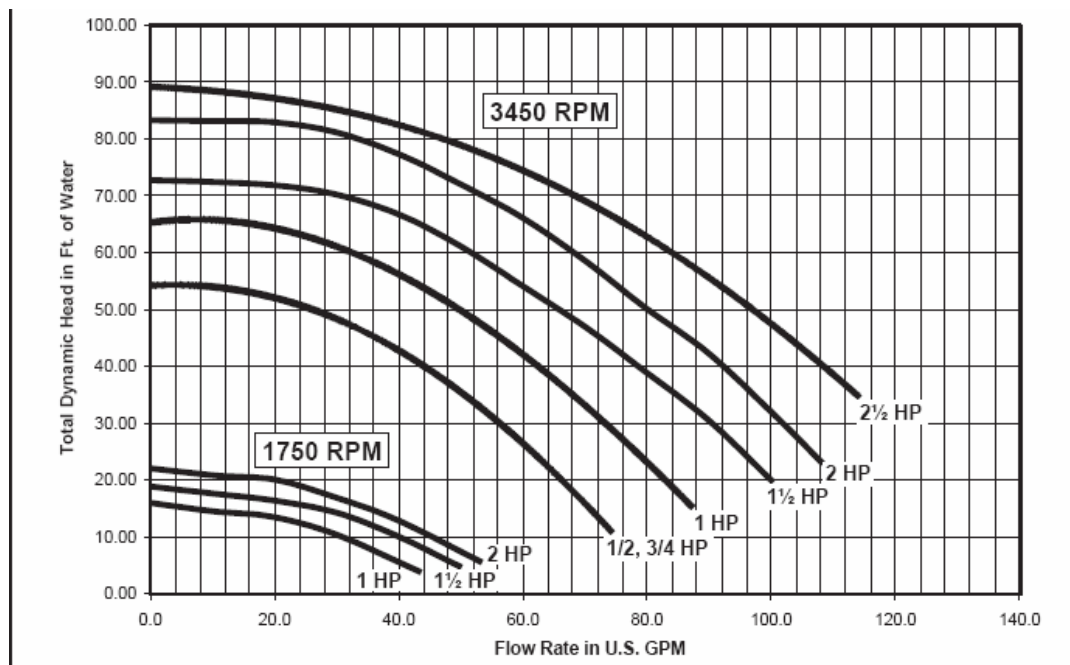

Dimensions

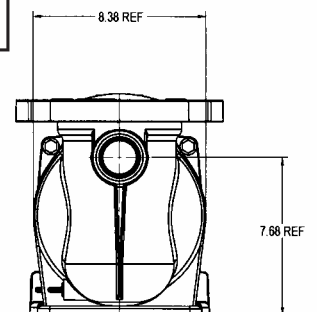
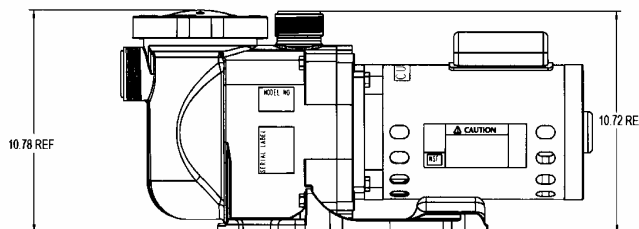

Ordering Number	HP	Voltage	Full Load Amps	Weight(Lbs.)
PPPHK2RA6D-101L	3/4	115/230V	10.5/5.4	38
PPPHK2RA6E -102L	1	115/230V	14.2/7.1	38
PPPHK2RA6F-103L	1-1/2	115/230V	16/8	40
PPPHK2RA6G-104L	2	115/230V	22.4/11.2	48
PPPHK2RAA6G-105L	2-1/2	230V	11.5	54

Dynamo® Pool Pump

Features

All components designed for maximum performance and economy in a swimming pool pump. The Dynamo® is self-priming design that ensures long life. It has reinforced fiberglass for strength and durability and a see-thru lid.



Performance

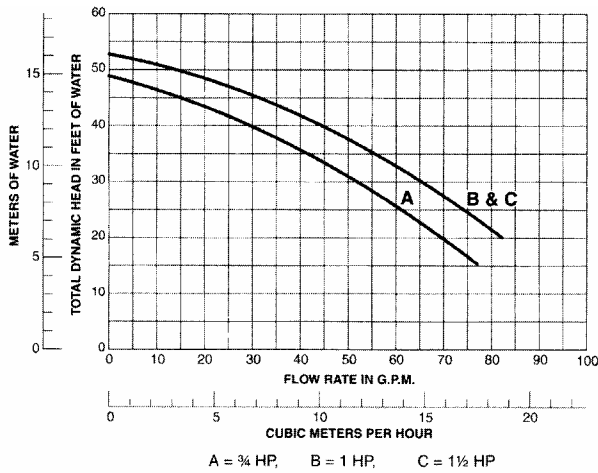

Dimensions

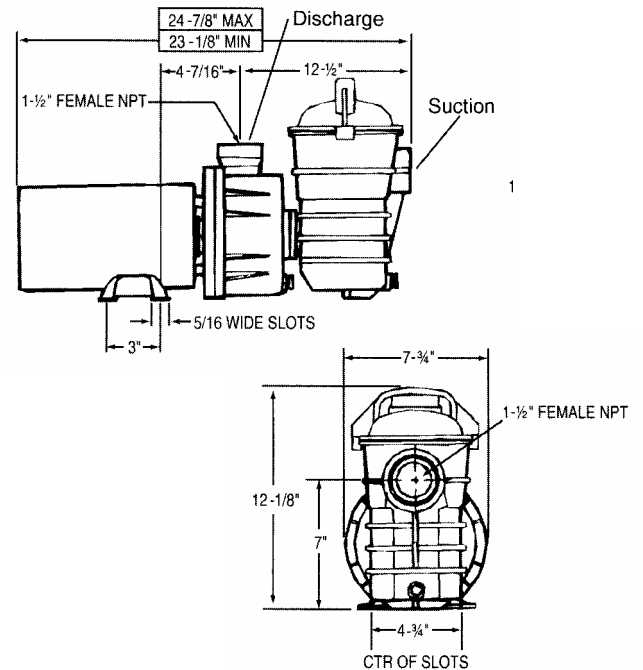

Ordering Number	Model No.	HP	Voltage	Full Load Amps	Weight(Lbs)
PP340103	DYNII-NI-3/4HP	3/4	115V	9.2	33
PP340104	DYNII-NI-1HP	1	115V	12	37
PP340106	DYNII-NI-1-1/2HP	1-1/2	115/230V	16/8	42

Challenger® High Flow Pool Pumps

Features

Fiberglass Reinforced Pump with Closed Impeller, Single Speed. Pump components are custom molded thermoplastic for superior strength and durability. All components developed and perfected through Computer Assisted Design for maximum operating expense.



Performance

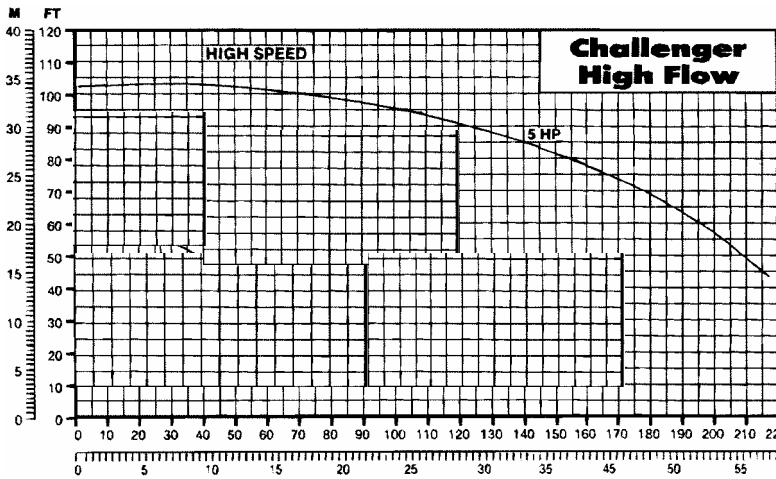

Dimensions

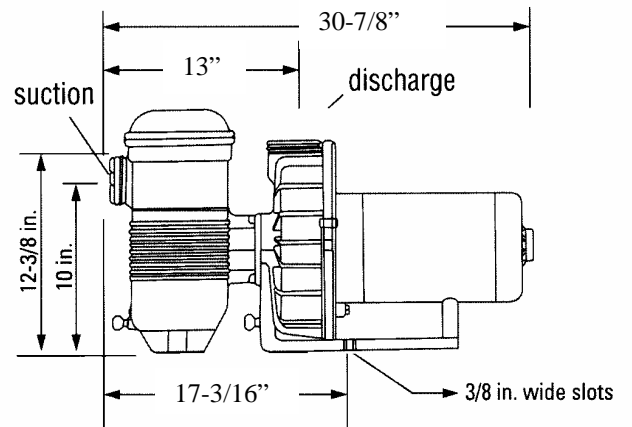

Ordering Number	Model	HP	Voltage	Full Load Amps	Weight(Lbs)
PP345210	CFII-NI-5FE	5	208/230V	21/19.4	70
3 Phase					
PP345300	CFII-NI-5FE.3PH	5	230/460V	13.4/6.7	70

Max-E-ProXF® High Performance Pumps

Features

- New hydraulic isolator separates priming water from pumping water for faster priming, more turbulence free flow and increased efficiency.
- Dual compartment heavy duty DT6 frame motor for simplified field wiring
- Union connectors included for connecting directly to 2.5" or 3" plumbing
- Extra large basket for easy debris removal.

Dimensions

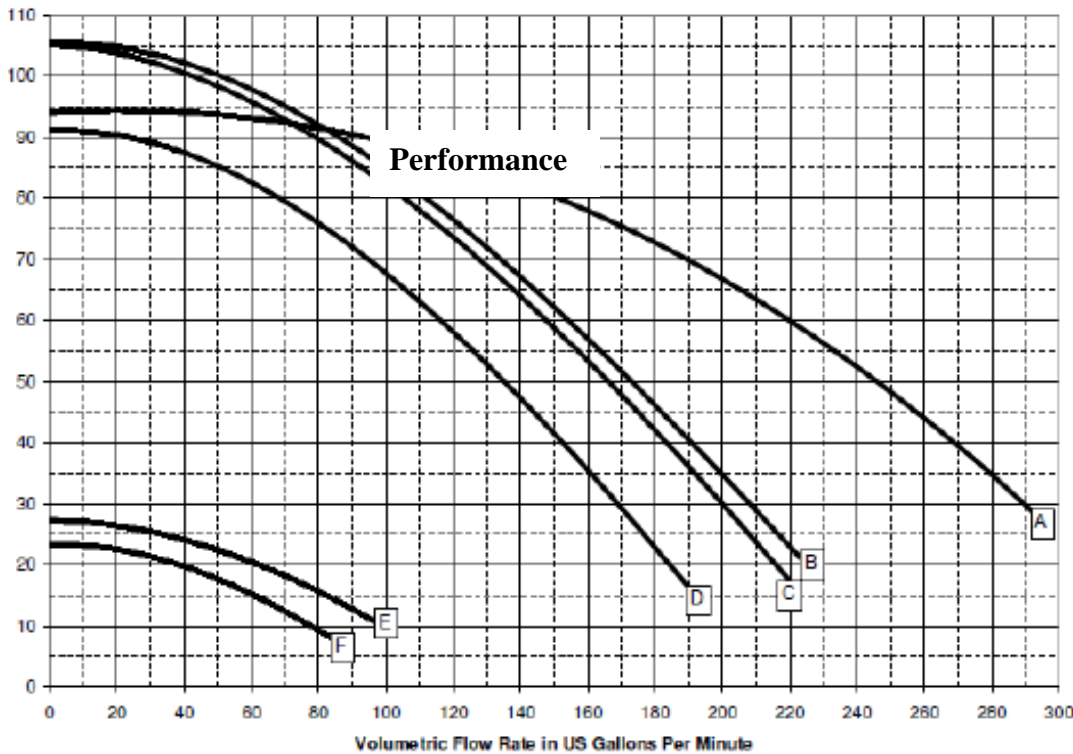
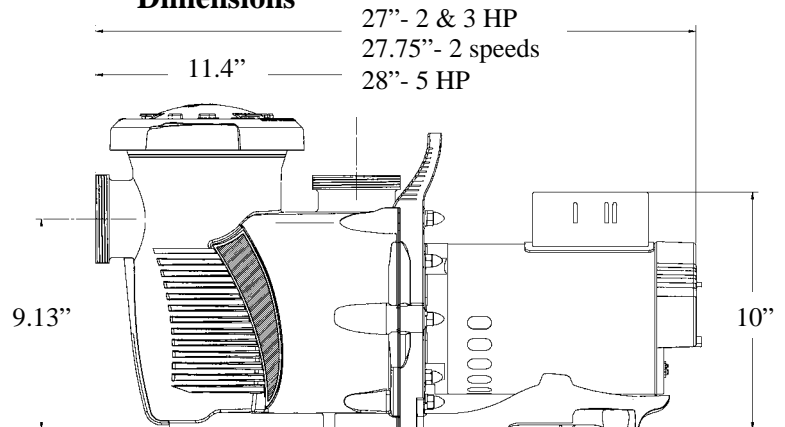

Line A XPE20

Line B XPE12

Line B,E XPDS12

Ordering Number	Model	HP	Voltage	Full Load Amps	Port Size	Weight(Lbs)
PP022010	XPE12	3	208/230V	15/13.6	2.5" x 2.5"	60
PP023011	XPE20	5	208/230V	22	or 3" x 3"	63
PP023008	XPDS12	3	208/230V	15.0/2.6		60

Bermuda™ Skimmers for Gunite Pools

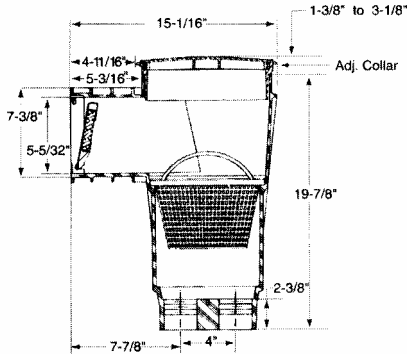

Features

White PVC Skimmer for concrete or gunite pools with 2" Slip ports.

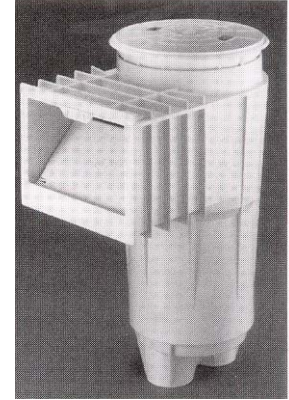

Ordering Number	Description	Weight(Lbs)
PP506300	2" Slip Ports Gunite Skimmer	10
PP506370	BKG 2" Slip Ports with Float Valve & Equalizer Valve	10

Bermuda Skimmer Accessories

Ordering Number	Description
PS506161	Vacuum plate/insert assembly, White

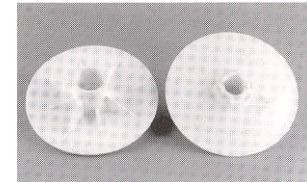

Residential Pool Drain Covers



Waterway main drain covers are compliant with the Virginia Graeme-Baker Pool and Spa Safety Act (ASME/ANSI A112.19.8-2007) and are UL Certified. They are designed for single or multiple drain use. The drain cover assembly includes frame and stainless steel screws with brass inserts.

Anti-Vortex Drain Covers

Ordering Number	Description	Flow Rate Floor (GPM)
WW640-2310V	8" Anti-Vortex Drain	100
WW640-2550V	8" Anti-Vortex 8" Main Drain 2" FPT Side x Bottom	

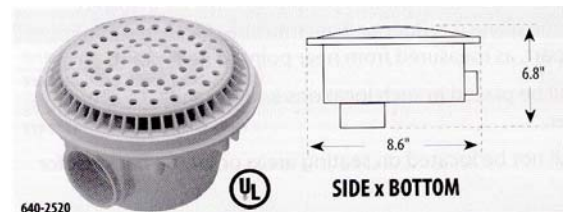



Frame & Grate Drain Covers



Ordering Number
WW640-4700 V
WW640-4720 V
WW640-4750 V

Description
9" x 9" Frame & Grate.
12" x 12" Frame & Grate.
18" x 18" Frame & Grate

Flow Rate Floor (GPM)
289
356
540



New StarGuard® Commercial Main Drains, from Pentair Water comply with provisions of the ASME/ANSI A112.19.8a-2008 standard and the Virginia Graeme Baker Pool and Spa Safety Act.



Ordering Number	Description	Flow Rate Floor (GPM)
PP500420	9" x 9" StarGuard Drain with 3"SLIP x FPT Side Port and 2"FPT x FPT Bottom Port Fiberglass Sump with Frame and Grate - White	270
PP500520	12" x 12" StarGuard Drain with 3"SLIP x FPT Side Port and 2"FPT x FPT Bottom Port Fiberglass Sump with Frame and Grate - White	360

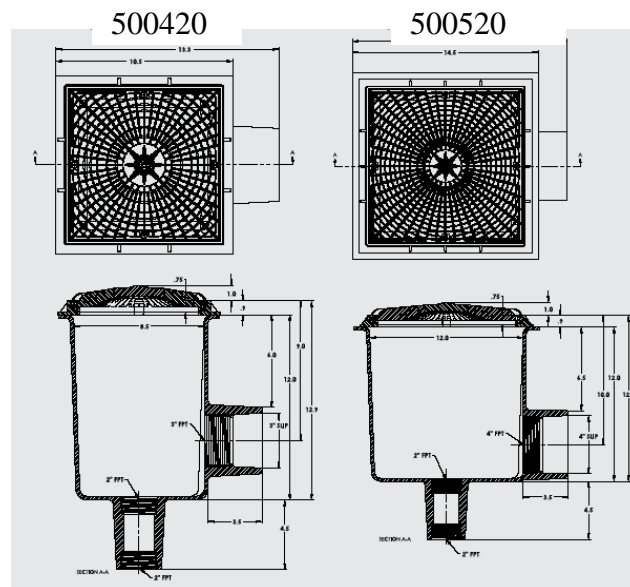

Pool Wall Fittings

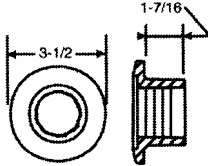

Ordering Number	Description
PP542405	Standard Body 1-1/2" threaded x 1-1/2" socket. White

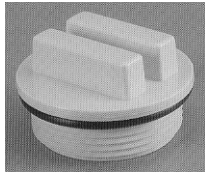

Ordering Number	Description
PS552622	1-1/2" Plug with O-Ring, White

Directional Inlet Fitting

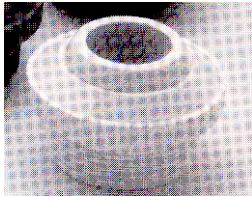

Ordering Number	Description
PP540014	1/2" Opening Directional Inlet Fitting White
PP540021	3/4" Opening Directional Inlet Fitting White
PP540028	1" Opening Directional Inlet Fitting White

Insider Directional Inlets



Ordering Number	Description
PP542000	1" Slip Inlet with snap-in 3/8" through 3/4" & pressure test disk. White
PP542002	1-1/2" Slip Inlet with 1/2" through 1" & pressure test disk. White

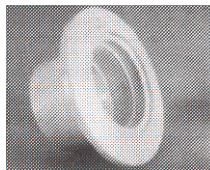

Ordering Number	Description
PP542423	2" Slip body for Sch. 40 PVC Pipe. White

Specialty Fitting

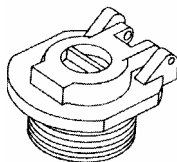

Ordering Number	Description
PSK12500	Snap-lock wall fitting



IntelliBrite™ 5g LED Underwater Color-Changing Light

The brightest and most efficient underwater LED color light available. IntelliBrite® automated color-changing pool and spa lights feature LED technology is the wave of the future in energy efficiency, lifetime value, quality of light, and controllability. With IntelliBrite, combinations of individual colored LEDs are mixed and matched to achieve a vibrant spectrum of colors. These combinations are power sequenced to illuminate and cycle through colors at varying speeds, and in different sequences of color. Combined with a custom reflector and unique lens design, the IntelliBrite LEDs offers super efficiency while being the brightest underwater LED light available

Features

- Set one of 5 predetermined fixed colors to match or create the mood for the evening - blue, green, magenta, white, and red.
- * Select from 7 popular “color shows” that come preprogrammed into IntelliBrite®

Ordering Number

PP601010	12 Volts, 30 ft. Cord	IntelliBrite® 5g Color LED
PP601011	12 Volts, 50 ft. Cord	IntelliBrite® 5g Color LED
PP601012	12 Volts, 100 ft. Cord	IntelliBrite® 5g Color LED
PP601013	12 Volts, 150 ft. Cord	IntelliBrite® 5g Color LED

Intellibrite White LED

IntelliBrite® White LED offers a brighter, more energy efficient alternative to incandescent white lighting. Utilizing its array of LEDs, it is also ideal for commercial applications.

Ordering Number

PP601305	12 volts, 30 ft cord	Intellibrite White LED
PP601306	12 volts, 50 ft cord	Intellibrite White LED
PP601307	12 volts, 100 ft cord	Intellibrite White LED
PP601308	12 volts, 150 ft. cord	Intellibrite White LED

Description

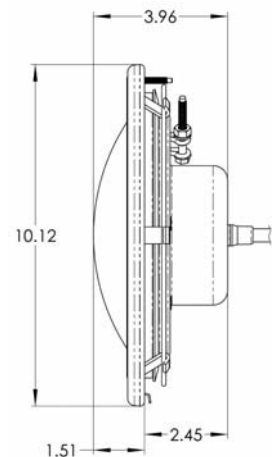

Dimensions

IntelliBrite Controller

IntelliBrite® Controller works with IntelliBrite Color Pool and Spa LED lights as well as IntelliBrite Landscape Lights. It can control and synchronize both sets of lights to create dazzling shows.

PP600054

IntelliBrite Controller



Notice: Underwriters Laboratories has listed Pentair Pool Products lights for use with Pentair Pool Products, American Products, Purex or PacFab niches only. To ensure proper grounding/bonding connections install only Pentair Pool Products lights in Pentair Pool Products, American Products, Purex or PacFab niches.



SAVI Pool and Spa Lights

A small but powerful lighting system designed to create even illumination and colorful lighting effects throughout your pool and spa. Fits into standard wall fittings. Requires a 12V transformer

Features

- Wire Direct to 12 VAC Low Voltage Circuit
- No Niche
- No Grounding
- No Bonding
- Installs into 1-1/2" fittings
- Easy Installation
- 5 static color modes
- 4 exciting color transition shows
- Auto Memory

Installation Requirements

- 4" minimum below waterline
- 14" minimum length of 1-1/2" diameter PVC behind wall fitting.
- Reduce to a 1" diameter conduit for the cable run to the transformer

Savi MELODY



Ordering Number

OWSAVI- MELODY100 14 Watts, 12 Volts, 100 ft. cord SAVI MELODY LED Color-changing light

Savi SOL



Ordering Number

OWSAVI- SOL100 28 Watts, 12 Volts, 100 ft. cord SAVI SOL LED Color-changing light

Savi MELODY BLANCO



Ordering Number

Description

OWMB-100 10 Watts, 12 Volts, 100 ft. cord SAVI MELODY BLANCO LED White light

OWMB-150 10 Watts, 12 Volts, 150 ft. cord SAVI MELODY BLANCO LED White light

Amerlite® Underwater Incandescent Pool Lights with S/S Face Rings

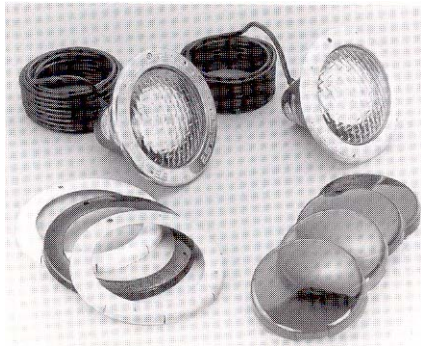

Amerlite®, the world standard of reliability for underwater lights, features a stainless steel shell, 8-3/8" prismatic tempered glass lens for superior light diffusion, gold diffused low water cutoff and stainless steel face ring with uni-tension clamp. Amerlite are UL listed to install in full-sized Pentair pool products, American, PacFab and Purex niches.

Ordering Number	Description	Weight (Lbs)
PP78431100	300 watt, 12 volts, 15 ft. cord Underwater Pool Light	10
PP78438100	300 watt, 12 volts, 50 ft. cord Underwater Pool Light	17
PP78435100	300 watt, 12 volts, 100 ft. cord Underwater Pool Light	20
PP78900100	Amerlite Kwik-Change Lens Cover (4 Assorted Colors)	2

Notice: Underwriters Laboratories has listed Pentair Pool Products lights for use with Pentair Pool Products, American Products, Purex or PacFab niches only. To ensure proper grounding/bonding connections install only Pentair Pool Products lights in Pentair Pool Products, American Products, Purex, or PacFab niches.

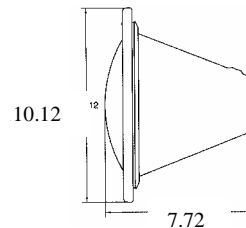

Dimensions

Stainless Steel Niche for Concrete Installation

Stainless Steel niche is formed with brass fitting. It has internal and external grounding lugs for use with either metal or PVC conduit.

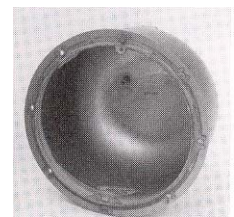

Ordering Number	Description	Weight (Lbs)
78210500	1" Top Hub Stainless Steel Niche for concrete installation	3

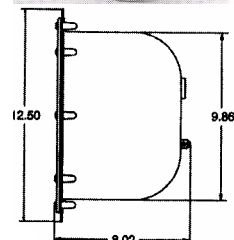

Pool Replacement Lamp



Ordering Number	Description
AJ21AR/40	300 Watt, 12 Volts Replacement Lamp
AJ500R/40	500 Watt, 120 Volts Replacement Lamp



PEDESTAL LAVATORIES

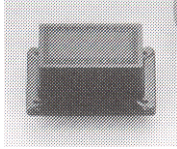

Polycarbonate Cover with Brass Base.
Built-in strain relief

Ordering Number	Description
PP78310700	3/4" x 1" x 3/4" Ports. Pool Junction Box



PX100 & PX300 Series Safety Transformers



These Safety Transformers are specifically designed to supply 12 volts to pool/spa lights, submersible fixtures and outdoor garden lights. A grounded shield between the primary and secondary windings assures safe operation and the built-in circuit protection will disconnect power to the transformer in case of defect or overload.

Applications:

• Pool Lights • Spa Lights • Garden Lights • Fountain Lights

Specifications:

PX100/S, PX300/S

Enclosure: Stainless steel or steel with electrostatically applied light beige finish

Mounting brackets top and bottom

7.25 in. (19.4 cm) H x 5.25 in. (13.3 cm) W x 4.5 in. (11.4 cm) D

Knockouts: Total of ten combination 1/2 – 3/4 in. knockouts, (2) right side, (2) left side, (2) back, (4) bottom

Ordering Number	Description
IIPX100S	100 Watt, 120-12-13 Volts Stainless Steel Pool Transformer
IIPX300S	300 Watt, 120-12-13-14 Volts Stainless Steel Pool Transformer

24" Residential Ladders



Astral Pool produce rails from flat stainless steel to be able to control all aspects of quality from start to finish. Automated, high tech rolling and bending equipment eliminates “wrinkles”. Designed with a fused in place non-skid surface and solid end blocking of resin filled with fiberglass. Treads do not warp or rock. The front and back lips are roll onto themselves to create a more user friendly “non-edge”.

Ordering Number:		Weight
AT07634	2-Steps Stainless Steel Ladder	20Lbs.
AT07635	3-Steps Stainless Steel Ladder	24Lbs.
AT07636	4-Steps Stainless Steel Ladder	28Lbs.

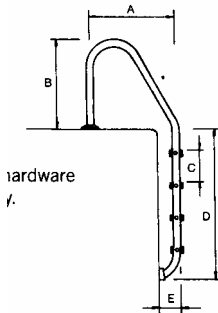

STEPS	A	B	C	D	E
2	24"	24"	10"	26"	7"
3	24"	24"	10"	36"	7"
4	24"	24"	10"	46"	7"

MADE IN SPAIN

Deck Mounted Stair Rail



Astral Pool produce rails from flat stainless steel to be able to control all aspects of quality from start to finish. Automated, high tech rolling and bending equipment eliminates “wrinkles”.

Ordering Number:		Weight
AT07659	Deck-Mounted Stair Rail	15Lbs.

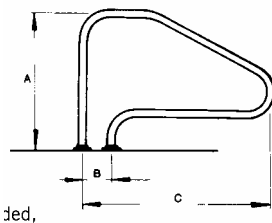

MADE IN SPAIN

	A	B	C
07659	32"	8"	50"

2 Bend Standard Length Hand Rail



Astral Pool produce rails from flat stainless steel to be able to control all aspects of quality from start to finish. Automated, high tech rolling and bending equipment eliminates “wrinkles”.

Ordering Number		Weight
AT07648	2-Bend Handrail 48”	9Lbs.
AT07649	2-Bend Handrail 60”	10Lbs.

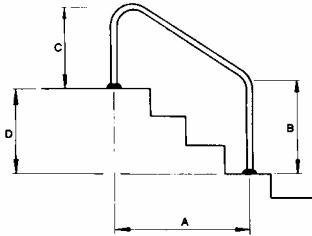

	A	B	C	D
07648	48"	31"	31"	25"
07649	60"	31"	31"	34"

MADE IN SPAIN

Stainless Steel Escutcheon Plate



Stainless Steel escutcheon plate to cover wedge anchors

Ordering Number	
AT06669	S.S. Escutcheon Plate

Ladder Anchors with Ground



Wedge Anchors for 1.9” O. D. Ladder

Ordering Number	
AT07661	Wedge Anchors w/ Ground

MiniMax® 100 High Performance Pool Heater

Features

The MiniMax® 100 is a compact, lightweight and efficient gas fired high performance aboveground pool heater that can be connected to schedule 40 CPVC or ABS pipe and have built-in tops. Reliable direct-spark ignition(DSI) system is available in propane or natural gas versions. Installs to 3,500 ft. altitude

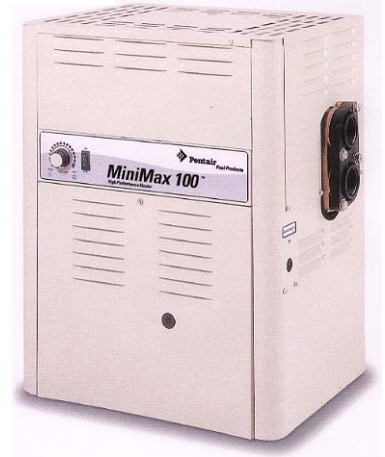

Ordering Number	Description	Weight (Lbs)
PP460347	Minimax 100-100,000 BTU Natural Gas, Electronic Ignition Heater	90
PP460348	Minimax 100-100,000 BTU Propane Gas, Electronic Ignition Heater	90

Performance (Heat Rise in One Hour)

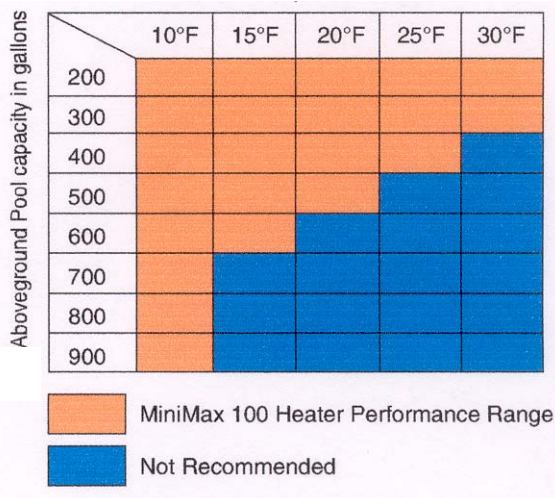

Dimensions

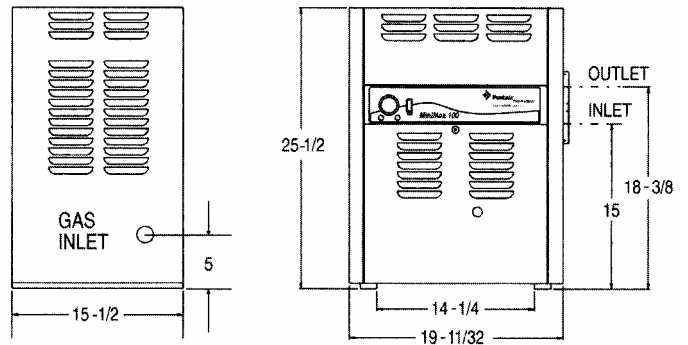

Master Temp™ High Performance Pool Heaters

Features

Master Temp™ is fast, efficient, compact, quiet, safe and eco-friendly. No matter what you're seeking in your swimming pool heater, Master Temp™ measures up. It has a very compact design for such a high performance heater allows for smaller overall equipment pads that won't intrude on your poolscape. A fully pre-mixed system with a highly efficient air and gas mixture lets Master Temp heat up fast. No long waits before enjoying your pool. Compare energy efficient ratings and you'll find Master Temp at the top of the list. Comfort and economy can go together. It has a hot surface ignition (no pilot light) and pushbutton digital control which make it easy to operate as your home heating system. Plus, user-friendly indicator lights make system operation and monitoring a snap. The easy-to view, rotating digital display places controls front and center, no matter how Master temp is positioned on your equipment pad. A tough, rustproof composite exterior handles the heat and weathers the elements. Eco-friendly, Master temp is certified for low NOx emissions and outperforms industry standards.

The safety features includes a water pressure switch that senses the pump is running to prevent overheating; High limit switches assure the heater turns off if water temperature exceeds factory-set limits; manual gas shut-off when service is required; stack flue sensor also guards against overheating.

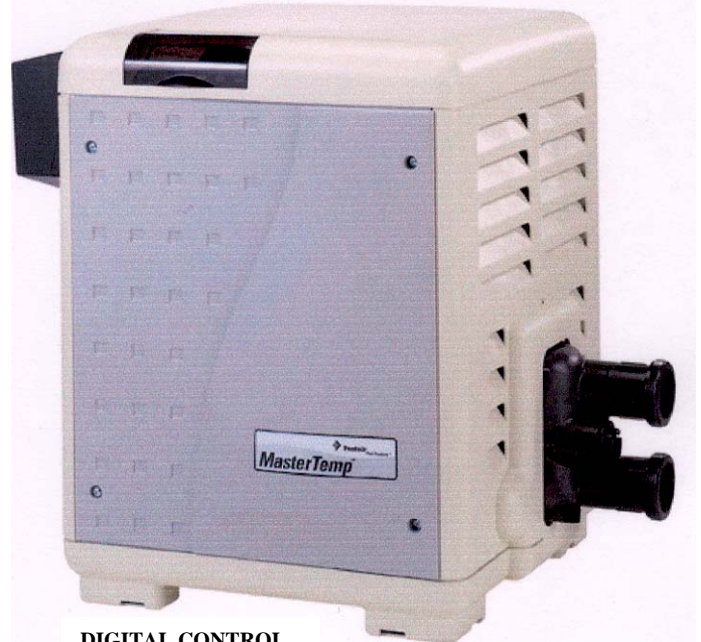

DIGITAL CONTROL

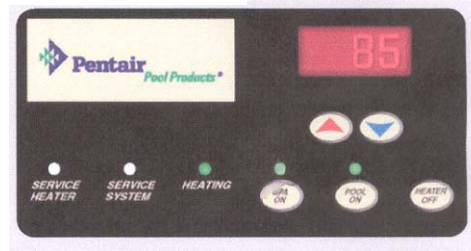

Ordering Number	Model	Description	Weight (Lbs)
PP460730	200	200,000 BTU/HR Natural Gas Pool Heater.	
PP460731	200	200,000 BTU/HR Propane Gas Pool Heater	
PP460732	250	250,000 BTU/HR Natural Gas Pool Heater	
PP460733	250	250,000 BTU/HR Propane Gas Pool Heater	
PP460734	300	300,000 BTU/HR Natural Gas Pool Heater	
PP460735	300	300,000 BTU/HR Propane Gas Pool Heater	
PP460736	400	400,000 BTU/HR Natural Gas Pool Heater	
PP460737	400	400,000 BTU/HR Propane Gas pool Heater	

Dimensions

All heaters measure
21L x 21W x 28H

Pool Sizing

°F Temperature Change/ 24 Hrs.	Heater Size				Heater Size			
	Model 200	Model 250	Model 300	Model 400	Model 200	Model 250	Model 300	Model 400
	Pool Capacity in Gallons				Pool Surface Area in Sq. Ft. at 5.5' Depth			
5	97,383	121,729	146,075	194,766	2,364	2,955	3,546	4,727
10	48,691	60,864	73,037	97,383	1,182	1,478	1,773	2,364
15	32,461	40,576	48,692	64,922	788	985	1,182	1,576
20	24,346	30,433	36,519	48,691	591	739	887	1,182
25	19,477	24,346	29,216	38,953	473	591	710	945
30	16,230	20,288	24,345	32,461	394	493	591	788
35	13,912	17,390	20,868	27,824	338	423	507	675
40	12,173	15,216	18,260	24,346	295	369	443	591

UltraTemp™ Heat Pump

Features



- 100% titanium heat exchanger assures corrosion-free performance for extra long life and value.
- LCD control board displays an intuitive, menu-driven readout with easy to follow, full word messages - no more codes.
- AutoSet (time clock over-ride) feature monitors water temperature and turns the water circulation pump on and off as needed to maintain desired pool temperatures
- Automatic defrost feature senses refrigerant temperature and prevents UltraTemp from freezing, allowing the heat pump to operate at even lower temperatures
- Compatible with All automated control packages
- Long-life corrosion resistant plastic composite cabinet stands up to severe climates and pool chemicals
- Emerson Copeland Scroll Compressor
- ETL listed for safe operation
- Thermostatic Expansion Valve (TXV) controls refrigerant flow for optimum efficiency and BTU output over a wider operating range
- Highest efficiency available, meets or exceeds existing codes and standards
- BTU and efficiency performance independently certified by the Air-Conditioning, Heating and Refrigeration Institute, AHRI.

Compare the Cost

Fuel Type	Cost/Per	BTU/\$.01
Electric	\$.075/KWh	455
LP Gas	\$.99/Gal	653
Oil	\$.99/Gal	979
Natural Gas	\$.65/Therm	1077
UltraTemp	\$.075/KWh	2093

Ordering Number	Description	BTUs/COP	Breaker Size	Wire Size	Weight
PP460932	UltraTemp Heat Pump 110	108,000/5.8	50 amp	8	270 Lbs
PP460933	UltraTemp Heat Pump 120	125,000/5.5	50 amp	8	270 Lbs.

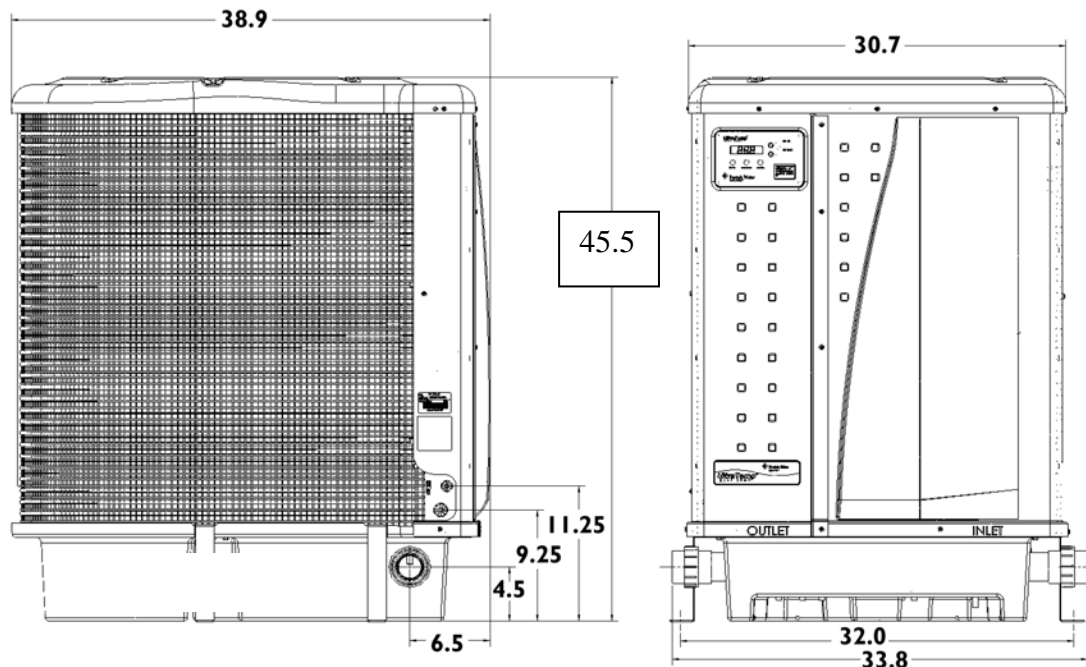

IntelliChlor® Salt Chlorinator

Turn ordinary salt into chlorine right in your pool

Electrolytic chlorine generation (or salt chlorine generation) with Intellichlor® Salt Chlorinator is the easiest, most effective, and convenient way to keep your pool water sparkling clean and sanitized. The IntelliChlor® Salt Chlorinator uses table salt to produce all the chlorine your pool needs, right in your pool – safely, effectively, and automatically.

An Eco Selected™ Choice: Using only natural table salt, the Intellichlor® Salt Chlorinator automatic chlorine generator creates pure chlorine in the pool and eliminates the need to buy, store, and add harsh chlorine products manually. In effect, fewer resources are used in the production, packing and transportation of these chemical compounds.



Features

- Cell blades rated for 10,000 hours of operation- five years of reliable chlorine output under normal operating conditions.
- Full diagnostic capabilities, including cell life tracking that communicates remaining hours of cell life in real-time. Captures all performance data daily (production settings, hours of operation, chlorine output, cell cleaning cycles, salt readings, and water temperature averages).
- Push-button operation and easy-to-view displays enable fast checking of salt levels, cell cleanliness, sanitizer output, and water flow.
- Automatic shut-off feature protects the unit and prolongs cell life under low water temperature conditions.
- On-time cycling prevents calcium and scale build-up to maximize cell life.
- Ability to communicate with IntelliTouch®, EasyTouch®, and SunTouch® Automation Systems.
- Certified to UL 1081 standard for safety.

Ordering Number

PP520554 Model IC20 Cell

- Produces up to .70 pounds of chlorine every 24 hours
- For pools up to 20,000 gallons

PP520555 Model IC40 Cell

- * Produces up to 1.40 pounds of chlorine every 24 hours
- * For pools up to 40,000 gallons

PP520556 IntelliChlor Power Center

- * 115 or 230 Volts 50/60 Hz.

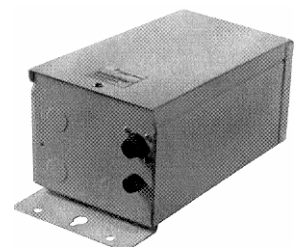

**IntelliChlor®
Salt Chlorinator**

System Schematic Diagram

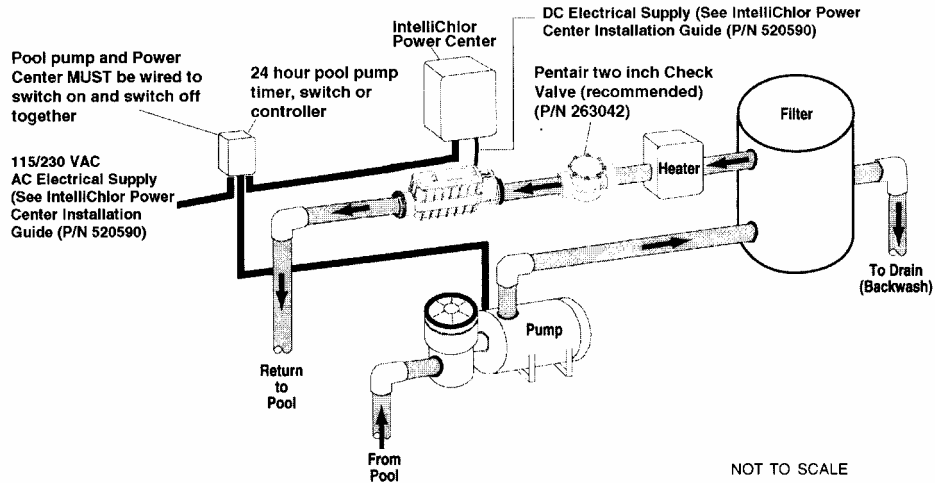

Table 1
Approximate Pounds (Kg) of salt needed to obtain 3,400 PPM

CHART FOR ADDITION OF SALT TO 3400 PPM											
Pool Gallons	0 ppm	250 ppm	500 ppm	750 ppm	1000 ppm	1250 ppm	1500 ppm	1750 ppm	2000 ppm	2250 ppm	2500 ppm
10,000	290 lb	267 lb	244 lb	221 lb	191 lb	168lb	145 lb	122 lb	99 lb	70 lb	46 lb
	132 kg	121 kg	111 kg	100 kg	87 kg	76 kg	66 kg	55 kg	45 kg	32 kg	21 kg
12,000	348 lb	320 lb	292 lb	265 lb	230 lb	202 lb	174 lb	146 lb	118 lb	84 lb	56 lb
	158 kg	145 kg	133 kg	120 kg	104 kg	92 kg	79 kg	66 kg	54 kg	38 kg	25 kg
14,000	406 lb	374 lb	341 lb	309 lb	268 lb	236 lb	203 lb	171lb	138 lb	97 lb	65 lb
	184 kg	170 kg	155 kg	140 kg	122 kg	107 kg	92 kg	77 kg	63 kg	44 kg	29 kg
16,000	464 lb	427 lb	390 lb	353 lb	306 lb	269 lb	232 lb	195 lb	158 lb	111 lb	74 lb
	211 kg	194 kg	177 kg	160 kg	139 kg	122 kg	105 kg	88 kg	72 kg	51 kg	34 kg
18,000	522 lb	480 lb	439 lb	397 lb	345 lb	303 lb	261 lb	219 lb	178 lb	125 lb	84 lb
	237 kg	218 kg	199 kg	180 kg	156 kg	137 kg	118 kg	99 kg	81 kg	57 kg	38 kg
20,000	580 lb	534 lb	487 lb	441 lb	383 lb	337 lb	290 lb	244 lb	197 lb	139 lb	93 lb
	263 kg	242 kg	221 kg	200 kg	174 kg	153 kg	132 kg	111 kg	89 kg	63 kg	42 kg
22,000	638 lb	587 lb	536 lb	485 lb	421 lb	370 lb	319 lb	268 lb	217 lb	153 lb	102 lb
	290 kg	266 kg	243 kg	220 kg	191 kg	168 kg	145 kg	122 kg	98 kg	69 kg	46 kg
24,000	696 lb	641 lb	585 lb	529 lb	460 lb	404 lb	348 lb	292 lb	237 lb	167 lb	111 lb
	316 kg	291 kg	265 kg	240 kg	208 kg	183 kg	158 kg	133 kg	107 kg	76 kg	51 kg
26,000	754 lb	694 lb	634 lb	573 lb	498 lb	438 lb	377 lb	317 lb	256 lb	181 lb	121 lb
	342 kg	315 kg	287 kg	260 kg	226 kg	198 kg	171 kg	144 kg	116 kg	82 kg	55 kg
28,000	812 lb	747 lb	682 lb	617 lb	536 lb	471 lb	406 lb	341 lb	276 lb	195 lb	130 lb
	368 kg	339 kg	310 kg	280 kg	243 kg	214 kg	184 kg	155 kg	125 kg	88 kg	59 kg
30,000	870 lb	801 lb	731 lb	662 lb	574 lb	505 lb	435 lb	366 lb	296 lb	209 lb	139 lb
	395 kg	363 kg	332 kg	300 kg	261 kg	229 kg	197 kg	166 kg	134 kg	95 kg	63 kg

Prowler™ 710 **Robotic Inground Pool Cleaner**



Specifications

Recommended pool size:
Up to 50 feet in length for inground pools.
Voltage in the water: 30V AC
Electrical specifications: 115 volts/
60 Hz/150 watts

Features

The Prowler™ 710 is the fastest and most effective robotic cleaner in its class, it features true “plug and play” convenience and operates totally independently of pool’s circulation system to cover and clean any dimension, form, or shape of inground pool up to 50 feet in length. A jet Drive propulsion system with a single, powerful motor drives the cleaner and enables total pool cleaning from floor to water line in one hour or less. The dual pressure wash jets lift sand, silt and algae of floors and walls-including surface pores where brushes can’t reach, and a powerful vacuum action removes fine particles and large debris. An internal filtration system removes contaminants and bacteria as small as two microns

Ordering Number	Description
PPP80710	Prowler™ 710 Robotic Inground Pool Cleaner

Prowler™ 720 **Robotic Inground Pool Cleaner**



Recommended Pool size: 20x50 feet
Drive and Pump Motor: 24V DC
Floating Cable Length: 60 feet
Electrical specification: 115V/ 60 Hz.

Features

Prowler™ 720 is the computer-controlled, programmed cleaner that scrubs and vacuums pool’s bottom, walls and steps and provides supplemental filtration of the pool water. Totally independent of pool circulation system, Prowler™ provides on-demand cleaning without running pumps. It requires no installation or hoses. Just plug it in and place it in the pool... It’s a totally self-contained cleaning and filtration system. The powerful vacuum action removes fine particles and large debris. The integrated filtration system captures dirt and debris in handy collection bag. The integrated filter reduces run times of your primary filtration system by 25% to save on pump energy use and normal wear and tear.

Ordering Number	Description
PPP80720	Prowler™ 720 Robotic Inground Pool Cleaner

Kreepy Krauly® Cruiser Inground Pool Cleaner

Kreepy Krauly® Cruiser features many design elements shared by the most popular suction-side cleaner in history, the Kreepy Krauly® Classic. Then we added performance features to make Kreepy Cruiser relentless in its pursuit of dirt and debris, while keeping it affordable and sensationally dependable. Superior vacuum power and extra-wide mouth capture large and small debris with ease. Silent flapper design provides quiet cleaning performance.



Ordering Number	Description
PPK60400	Kreepy Krauly® Cruiser Inground Pool Cleaner

Vac-Mate®

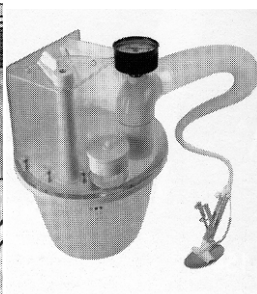
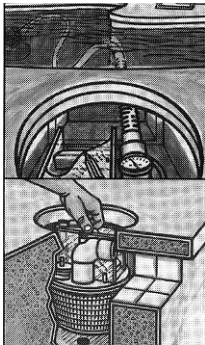

Features

The addition of a Vac-Mate in most skimmers allows you to control a suction cleaner while maximizing surface skimming...all with one simple setting of the control handle.

Ordering Number	Description
PPR211100	Vacuum/ Skimmer Attachment
PPR36060	Adapter Kit for Pentair Skimmers

Flexible Pool Vacuums For Concrete Pools

Features

Four lead weights under plastic covers and adjustable solid molded wheels. Unique stainless steel spring device on snap-adapt handle holds vacuum flush with wall

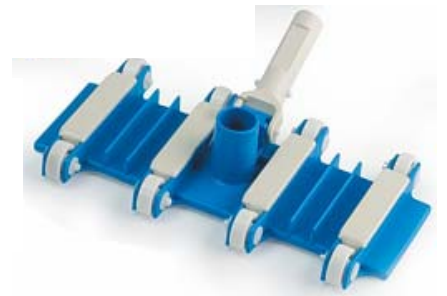

Ordering Number	Description
PPR201384	Model 201 Low profile 14" Flex-A-Vac

Features

ABS and polyethylene with 6 fully-enclosed lead weights. Adjustable wheels swivel in any direction. 19" body has 1-1/2" vacuum swivel adapter which allows hose to move freely without twisting.

Ordering Number	Description
PPR201126	Swivel Wheel 19" Flexible Vacuum

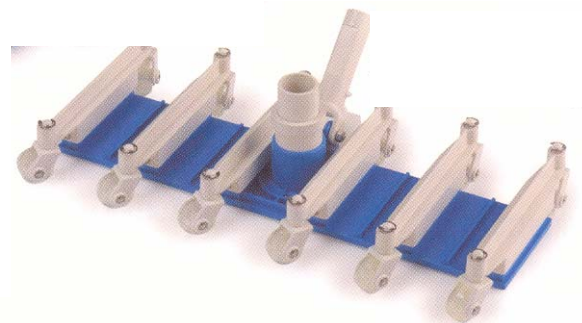



Leaf Skimmer

Features

Sturdy aluminum frame construction with a polyester netting for greater resistance to sun light and pool chemicals. White Mar-Free plastic rim with full-sized aluminum handle with plastic spring clip and end cap.



Ordering Number	Description
AJ1020	Aluminum Leaf Skimmer



Leaf Rakes

Features

Sturdy aluminum frame construction with a polyester netting for greater resistance to sunlight and pool chemicals. White Mar-Free plastic rim with full-sized aluminum handle with plastic spring clip and end cap. It has wide throat and deep pocket for easy removal of leaves and debris.

Ordering Number	Description
AJ2020	Aluminum Leaf Rake

Telescoping Pole

Features

High quality drawn aluminum tubing with attractive blue anodized outer pole and bright anodized inner pole. It has high strength wear resistant camlocks. It extends to 15-1/2".

Ordering Number	Description
AJ816-I	8'- 16' Pole with internal camlocks



Features

High quality drawn aluminum tubing with sleek satin silver outer pole and bright anodized inner pole. It has high strength wear resistant camlocks. It extends to 23-1/2".

Ordering Number	Description
AJ1224-I	12'- 24' Pole with internal camlocks



Deluxe Wall Brush



Features

UV stabilized nylon bristles with a strong die cast aluminum back. The snap-adapt handle fits most poles.

Ordering Number	Description
PPR111046	18" White nylon curved-aluminum back Pool Brush



Deluxe Algae Brush

Features

A quality stainless steel bristles with a strong die cast aluminum back. The snap-adapt handle fits most poles. It is perfect for removing tough algae on plaster surfaces.

Ordering Number	Description
PPR111626	9" Stainless Steel –aluminum back Algae Pool Brush



Pool Vacuum Hose



Features

These heavy duty vacuum hoses are crush proof with smooth interior and UV resistance. They have swivel cuff.

Ordering Number	Description
WA39-802	PA Spiral Roll-Blue Crown Hose with Swivel Cuff
WA39-806	PA50B- 1-1/2" x 30' Hose
WA39-810	PA50B-1-1/2" x 40' Hose
WA39-810	PA50B-1-1/2" x 50' Hose
WA39-850	CR Spiral Roll-White Crown Hose with Swivel Cuff
WA39-850	CR50B-1-1/2" x 30' Hose

Thermometer

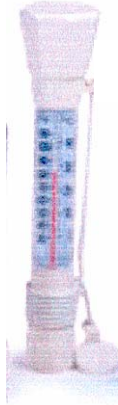

Features

This E-Z Read Combo Sink or Float Thermometer made of ABS material with shatterproof magnifying lens. The snap-on/off flotation top has 3 feet leash with anchor plate.

Ordering Number

PPR141200 No. 136 Sink or Floating Thermometer

Test Kits

Features

The “All-in-one” 4 way Test Kit will test Cl , pH, Acid demand, and Total Alkalinity. The Lucite test cell has a wide standard. It has 1 oz. bottles of solution # 1, # 2, #3 and ½ oz. bottles of solution # 4 and # 5. Also includes a water test booklet.

Ordering Number

Description

PPR151186 78HR “All-in-one” 4 way Test Kit



Features

The 2 ‘n 1 Test for pH and Chlorine .It has Sturdy hinge case and Waterproof instruction. The Solid Test Block has Vivid Color Standard. Large ¾ oz. OTO and Phenol Red

Ordering Number

PPR151076 2 ‘n 1 Test Kit for pH and Chlorine



Features

This test kit is to determine parts per million of Cyanuric Acid in the pool water. The Test Vial is designed for positive read out. It has 8 oz. reagent, instruction in Styrene box with clear top.

Ordering Number

PPR151226 No.79 Cyanuric Acid Test Kit



Floating Dispensers



Features

This Floating Chemical Dispenser has linear polyethylene construction and foam filled for added buoyancy. It has a twist lock cap and adjustable control ring. It holds six 3 inch or 3 lbs. of 1 inch tablets.

Ordering Number	Description
PPR171086	Floating Chemical Dispenser

Rainbow Automatic Chlorine Feeders



Features

Years of customer use and satisfaction have proven the Rainbow Feeders to be the performance leader in pool chemical dispensers. It is a completely enclosed system with no escaping gases and no special venting is required. The model 320 is for permanent installation in return line of new or existing pools. It installs in return line on pressure side of pump downstream of all equipment. Standard with 2 inch slip PVC fitting and adapters for 1-1/2 inch.

It holds 11 large or 98 small trichlor slow dissolving tables. Treats from 6,500 up to 27,000 gallons bottom feed and from 18,000 up to 70, 000 gallons top feed.

Ordering Number	Description
PPR171096	No. 320 In-Line Automatic Chlorine Feeder

Time Switches Pool Controls

Features

The T100 series is designed for industrial, commercial and residential applications. Highest HP ratings in the industry for loads up to 40 amps, providing direct 24 hr. control of most loads. Provides 1 to 12 "ON/OFF" operation each day with minimum ON/OFF times of 1 hour. All models equipped with one "ON" and one "OFF" tripper

Specifications

Standard Case

The case is drawn steel 7-3/4" high, 5" wide, and 3" deep. in gray finish. Spring hasp, with hole for lock, holds permanently attached, side hinged door closed. It has three mounting holes on back plus handy box mounting holes. It has combination 1/2"- 3/4" nominal knockouts, one on back and each side of case and two on bottom.

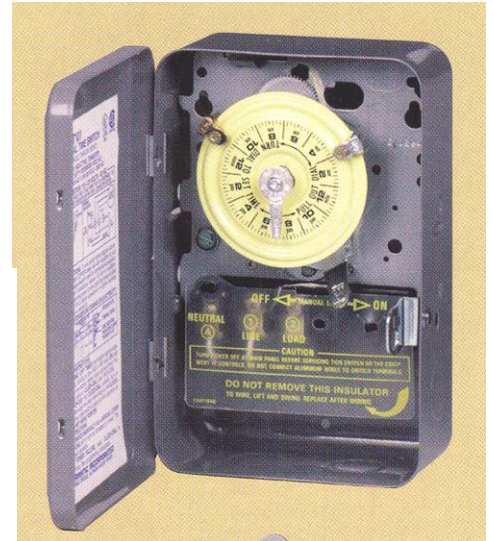

ORDERING NUMBER	SWITCH	CLOCK MOTOR VOLTS	AMPS (per pole)	H.P. RATING
IIT101	SPST	125	40	2
IIT104	DPST	208-277	40	5
IIT101-50	SPST	110V .50 Hz.	40	2
IIT104-50	DPST	220V .50HZ	40	5

Specification

Plastic Case

Made of heavy-duty industrial grade plastic, Intermatic's rainproof all plastic case is perfect for applications where high humidity and or dust can be a problem. It was developed for use with pool equipment. A hasp with a hole for lock holds the side-hinged door closed. A bracket plus two holes below the switch on the back are for mounting. It has five combination 1/2-3/4" nominal knockout, one on back and each side of the case and two on the bottom.

ORDERING NUMBER	SWITCH	CLOCK MOTOR VOLTS	AMPS (per pole)	HP RATING
IIT101P3	SPST	125	40	2
IIT104P3	DPST	208-277	40	5

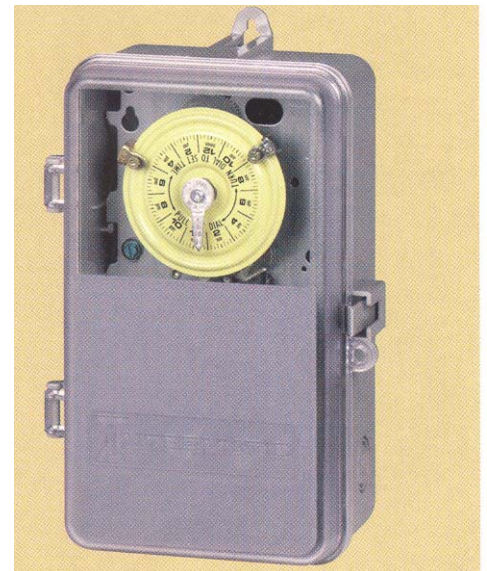

POOL ACCESSORIES

Single Entry Ball Valve

**PVC White
Socket Ends**



Pressure Rating @ 73°F, Water

1/2" - 2" 235 psi
3" - 4" 150 psi

Ordering Number	Size
SM2412-005W	1/2"
SM2412-007W	3/4"
SM2412-010W	1"
SM2412-012W	1-1/4"
SM2412-015W	1-1/2"
SM2412-020W	2
SM2412-030W	3
SM2412-040W	4



**Maximum Service
Temperature**

PVC = 140°F

**Pressure Deratings Apply
Rated for Vacuum Service**



REPLACEMENT FILTER ELEMENTS

ORDERING NUMBER	DESCRIPTION	FILTER MODEL
UN4326	25 SQ FT Dynamic Replacement	R173429
UN4950	50 SQ FT Dynamic Replacement	R173434
UN4999	100 Sq FT Dynamic Replacement	S173436
UNC5601	25 SQ.FT Jacuzzi Front Load Replacement	CF25
UNC5624	25 SQ.FT Jacuzzi Whirlpool Replacement	
UNC5625	25 SQ.FT Jacuzzi Replacement	CFT-25
UNC7660	60 SQ.FT Pentair Replacement	MY-60
UNC7676	75 SQ.FT Hayward Replacement	CX750-RE
UNC7699	100SQ.FT Pentair Replacement	MY-100
UNC8409	90 SQ.FT. Hayward Replacement	CX900-RE
UNC8412	120 SQ.FT Hayward Replacement	CX1200-RE
UNC8417	175 SQ.FT Hayward Repkacement	C1750-E
UNC8600	80 SQ.FT Hayward Replacement	CX800-RE
UNC8610	100 SQ.FT Hayward Replacement	CX1100-RE
UNC9405	50 SQ.FT Predator Replacement	
UNC9407	75 SQ.FT Predator Replacement	
UNC9410	100 SQ.FT Predator Replacement	
UNC9415	150 SQ.FT Predator Replacement	
UNC9419	200 SQ.FT. Predator Replacement	
UNC9475	75 SQ.FT. Jacuzzi Replacement	CFR-75
UNC9478	150 SQ.FT Jacuzzi Replacement	CFR-150
UNC9480	80 SQ.FT Jacuzzi Replacement	SHER 80
UNC9481	120 SQ.FT Jacuzzi Replacement	SHER 120
UNC9482	160 SQ.FT Jacuzzi Replacement	SHER 160
UNC9483	200 SQ.FT. Jacuzzi Replacement	SHER 200
UN C9650	50 SQ.FT. Jacuzzi Replacement	CFR-50
UN C9699	100 SQ.FT. Jacuzzi Replacement	CFR-100
UNUHDSR50	50 SQ.FT. Sta-Rite Replacement	
UNUHDSR100	100 SQ.FT. Sta-Rite Replacement	
UNUHDSR137	137 SQ.FT. Sta-Rite Replacement	



Deck Jet Water Feature



Features

Perhaps nothing else soothes the soul like the sight and sound of moving water. That's why water features are such a popular and fast-growing enhancement to pools and poolside environments. With Pentair Water's Deck jet water effects, you can add to the peace and tranquility of your poolside experience a number of ways...more economically than ever before. Deck Jet water effects can be cast into concrete desks and gunite walls or integrated into surrounding landscapes. Each Deck Jet unit comes with 5 interchangeable nozzles- 3 single streams, fan jet and tri-cluster

Ordering Number
PP580000

Description
Deck Jet with five interchangeable water effect eyeballs

Performance

		THROW DISTANCE IN FEET						
		2	3	4	5	6	7	
Fan	gpm	-	1	1.2	1.3	1.5	1.9	
	psi	-	1.8	2.2	2.6	3.6	4.8	
	spread	-	12 in.	24 in.	36 in.	60 in.	96 in.	
	height	-	12 in.	18 in.	24 in.	36 in.	48 in.	
3 Stream	gpm	1.3	1.6	1.9	2.2	2.5	2.8	
	psi	2	2.5	3.5	4.2	5	6	
	spread	8 in.	12 in.	18 in.	20 in.	24 in.	30 in.	
	height	9 in.	14 in.	20 in.	24 in.	30 in.	36 in.	
3/16 in. Single Stream	gpm	0.4	0.5	0.7	0.7	0.8	0.9	
	psi	1.5	2	2.4	2.8	3.2	3.6	
	height	10 in.	15 in.	21 in.	25 in.	31 in.	38 in.	
1/4 in. Single Stream	gpm	1.2	1.5	1.8	2.0	2.2	2.5	
	psi	2	2.5	3.2	4	4.6	5.5	
	height	10 in.	16 in.	22 in.	27 in.	32 in.	40 in.	
5/16 in. Single Stream	gpm	1.5	1.9	2.3	2.6	2.9	3.2	
	psi	2	2.8	3.8	4.5	5.4	6.2	
	height	6 in.	9 in.	14 in.	17 in.	20 in.	26 in.	



Water Features Stream Jet



Features

Elegant streams of water. The Stream Jet works well in a combination to create a canopy of arching water lining a classic pool. This directionally adjustable clear stream nozzle is designed for applications that require flush deck level mounting such as swimming pool decks. The gentle slender column of water produced by the 3/8 inch diameter opening is recommended as a small to medium small water feature nozzle. It has machined cast bronze construction. It has a 1" water connection.

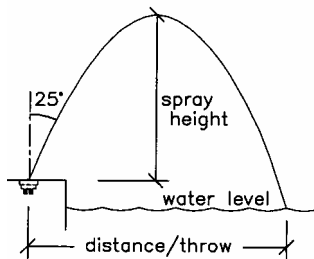

Performance (at 25 Degrees)

Distance or throw	1'	2'	3'	4'	5'	6'	7'	8'	9'	10'
Gpm	3	3.5	4.1	5	5.5	6	7	7.2	7.5	8
Head	1.5'	3'	3'	4'	5'	6'	9'	9.5'	10'	12'
Spray Height	0.6'	1.3'	2'	2.6'	3.4'	4'	4.5'	5.2'	6'	6.5'

Ordering Number	Description
CRWMD 100	Deck Level Stream Jet

Quick Pipe and Pump Sizing (Distance from nozzle to pump 100' max.)

No. of Jets	Main Pipe Diameter	Suction Pipe Diameter	Pump		
			gpm	head	hp
1	1"	2"	8	26'	3/4
2	1"	2"	16	49'	3/4
3	1-1/2"	2"	24	49'	3/4
4	1-1/2"	2"	32	45'	1
5	2"	2"	40	30'	1
6	2"	2"	48	37'	1
7	2"	2"	56	45'	1-1/2
8	2"	2"	56	45'	2
9	2"	2"	72	64'	2

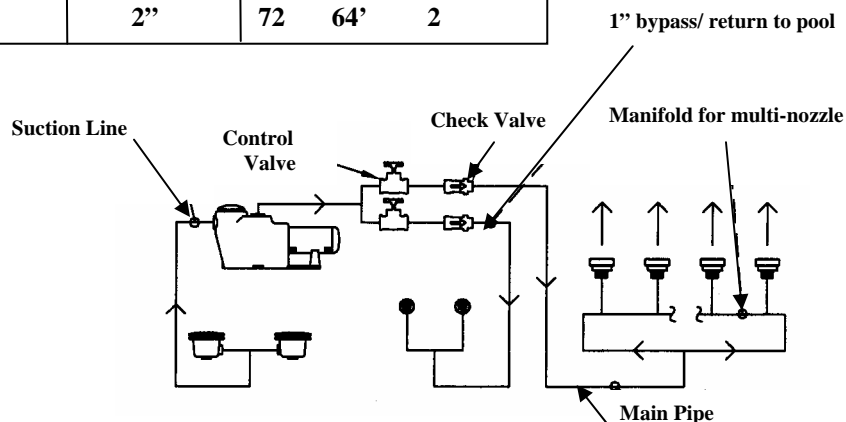



Water Feature FyreFly Jet

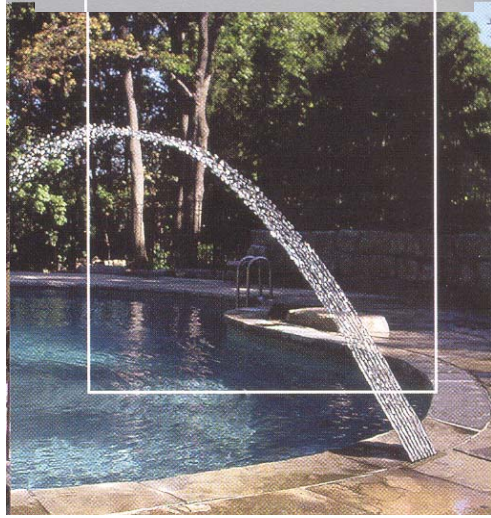
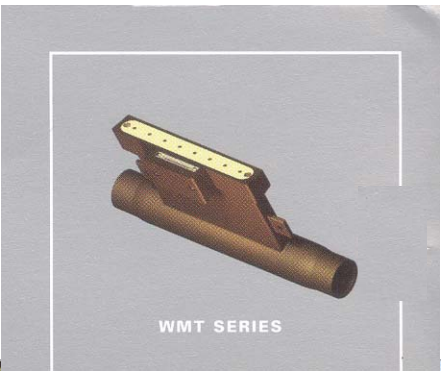

Features

Most pool designs can be complimented with this versatile cast in place jet. Eight 3/16" sparkling streams form a wide arch, graceful, but with significant mass and form. Single jets can act as accents while groups will form a strong focal point of water and sound. The FyreFly Jet is constructed in cast bronze, brass and stainless steel with copper ground lug. The nozzle is removable for periodic cleaning. For in deck mounting the jet is machined at static angle of 40 degrees (measured from vertical) which gives a graceful low arch ideal for large pools. Water Inlet: 2 x 1-1/2" npt female

Nozzle effect

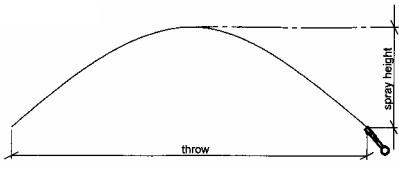
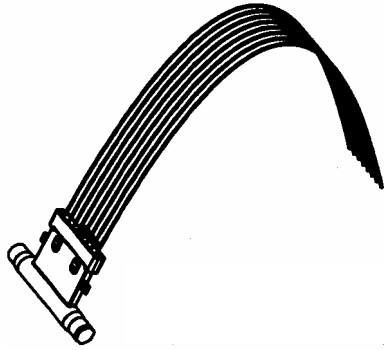

Ordering Number **Description**
CRWMT120A50- 40 degree nozzle w/ 8-3/16" Dia. Heavy sprays

Performance	WMT120A501					
Throw, ft	2	4	6	8	10	12
spray height, ft.	0.7	1.3	1.8	2.3	2.8	3.5
gpm	6.5	9.0	10	12.5	14.2	15.9
head, ft	2.3	3.6	5	6.4	7.8	9.7

No. of Jets	main pipe diameter	suction pipe diameter	gpm	pump head,ft	hp
1	1-1/2"	1-1/2"	16	19	3/4
2	2"	2"	32	20	3/4
4	2-1/2"	2-1/2"	64	35	2

Water Features

Oasis Original Waterfall

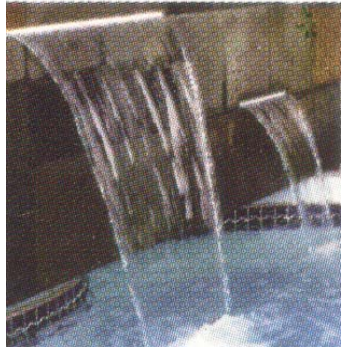

Features

The original Oasis Fall™ is one of the most popular waterfalls on the market. It creates a beautiful smooth sheet flow effect. It has a bottom or back feed

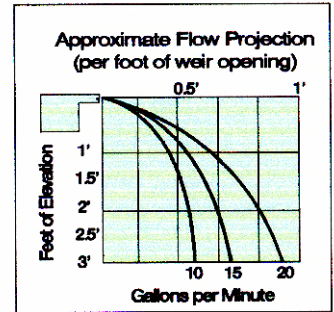

Ordering Number

Ordering Number	Description
OWOAWF-12EL-9	12" Backfeed PVC Waterfall with 9" extended Lip
OWOAWF-18EL-9	18" Backfeed PVC Waterfall with 9" extended Lip
OWOAWF-24EL-9	24" Backfeed PVC Waterfall with 9" extended Lip
OWOAWF-36EL-9	36" Backfeed PVC Waterfall with 9" extended Lip
OWOAWF-48EL-9	48" Backfeed PVC Waterfall with 9" extended Lip
OWOAWF-60EL-9	60" Backfeed PVC Waterfall with 9" Extended Lip

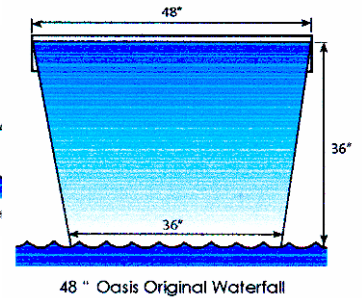
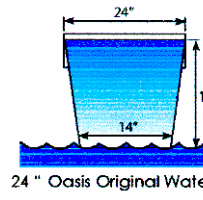
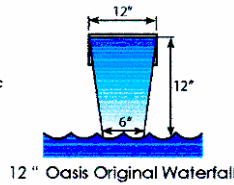
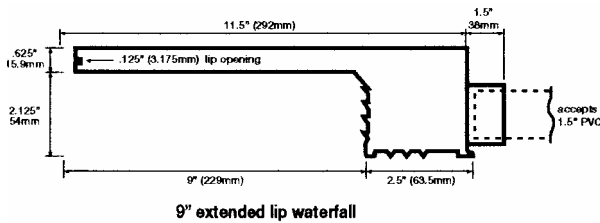

Oasis Rainforest Fall

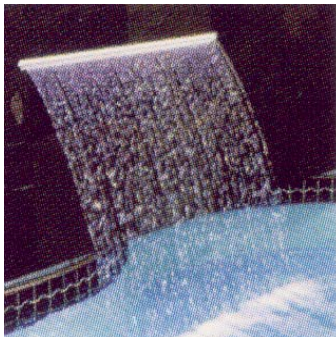

The Rainforest™ creates a beautiful unique visual texture and tranquil, mesmerizing sound.

Ordering Number

Ordering Number	Description
OWOARF-18EL-9	18" Backfeed PVC Rainforest Fall with 9" extended Lip
OWOARF-24EL-9	24" Backfeed PVC Rainforest Fall with 9" extended Lip
OWOARF-36EL-9	36" Backfeed PVC Rainforest Fall with 9" extended Lip
OWOARF-48EL-9	48" Backfeed PVC Rainforest Fall with 9" extended Lip
OWOARF-60EL-9	60" Backfeed PVC Rainforest Fall with 9" extended Lip

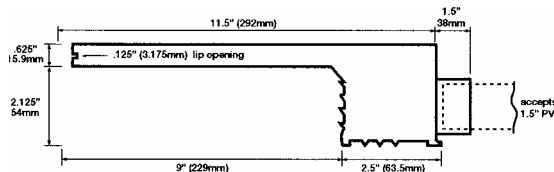
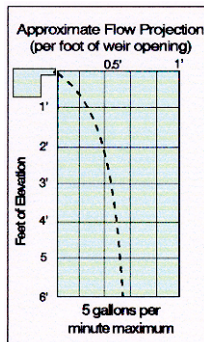

Water Features

Oasis Arch Fall



Features

The Oasis Arch Fall creates an elegant arc of falling water. Great for giving extra height to areas with low walls or risers

Ordering Number

Description

OWOAAF-12EL-9	12" Backfeed PVC Arch Fall with 9" extended Lip
OWOAAF-18EL-9	18" Backfeed PVC Arch Fall with 9" extended Lip
OWOAAF-24EL-9	24" Backfeed PVC Arch Fall with 9" extended Lip
OWOAAF-36EL-9	36" Backfeed PVC Arch Fall with 9" extended Lip
OWOAAF-48EL-9	48" Backfeed PVC Arch Fall with 9" extended Lip

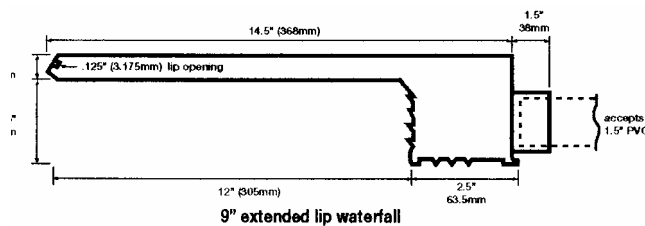
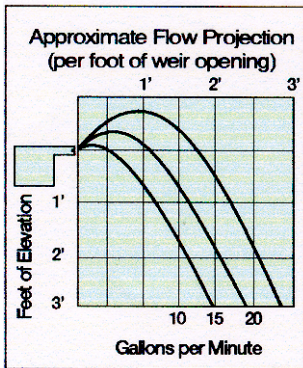

Technical Data for Waterfall Installation

Hydraulic Guidelines Chart

- Use minimum of 1-1/2" pipe
- Use minimum of 2" pipe for runs in excess of 60' or if waterfall is over 5'.
- Dedicated plumbing lines are recommended.
- Maximum recommended flow for a typical installation:

1.5" pipe	for 60 gpm
2" pipe	for 100gpm
2.5" pipe	for 140gpm
3" pipe	for 225gpm

WATER FLOW REQUIREMENT CHART FOR 1' TO 4' MODELS

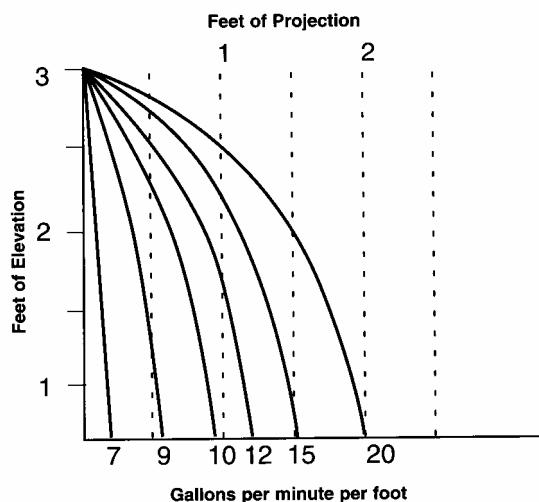

Typical Pump Performance at 50' of Head

3/4 HP	=	58 gpm
1 HP	=	68 gpm
1.5 HP	=	93 gpm
2 HP	=	106 gpm
3 HP	=	140 gpm

Chlorine Generators Replacement Parts

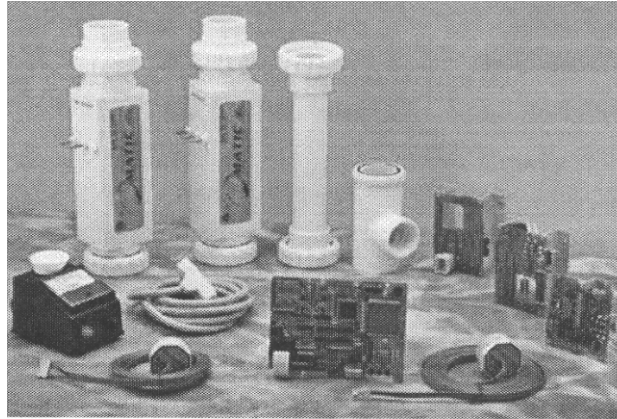

Ordering Number	Description
CLECR100	Replacement Electrolytic Cell for CM601 Generator
CLECR050	Replacement Electrolytic Cell for CM301 Generator
CLFSS102	Replacement 8' Cord Flow/Salinity Sensor Clormatic II
CLPSD001	Replacement Back Circuit Board for CM601 Clormatic II
CLPSD005	Replacement Back Circuit Board for CM301 Clormatic II
CLPSD002	Replacement Front Circuit Board All Models Clormatic II
CLFSS302	Replacement 8' Cord Flow/Salinity Sensor Clormatic III
CLPSD301	Replacement Back Circuit Board for CM301 Clormatic III
CLPSD302	Replacement Front Circuit Board All Models Clormatic III